



Quite possibly the world's easiest mounts to install!

Includes
Step-by-Step
Manual & DVD

TV Wall Mounting Kits

FOR
DUMMIES

Mounting Kits for 12" - 84" Flat Screen Televisions



*The easiest way
to sell and
install mounts!*

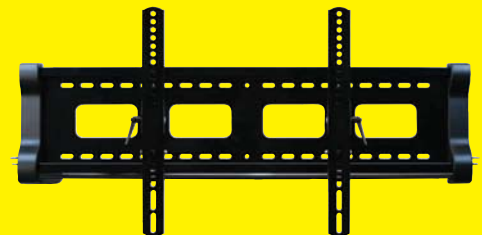



Quite possibly the world's easiest mounts to install!

TV Wall Mounting Kits FOR DUMMIES

Mounting Kits for 12" - 84" Flat Screen Televisions

- ✓ Professional-quality Bell'O mounts
- ✓ Solid heavy-gauge construction
- ✓ Easily recognizable packaging from a trusted brand
- ✓ Increase your attachment rate
- ✓ Carry fewer mounts to fit more TV sizes
- ✓ Cut down on DIY customer service issues

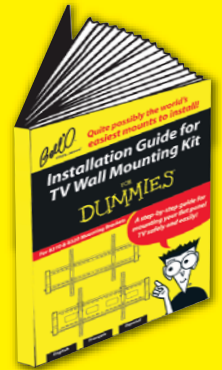

Step-by-Step DVD and Manual



The easiest way to sell and install mounts!



When consumers look for high-quality, precision-engineered, home theater furniture they turn to Bell'O®. Heavy consumer advertising, media coverage, and market presence has made Bell'O® one of the best known brands in the consumer electronics market.



When consumers look for assistance with unfamiliar tasks they turn to For Dummies® reference guides more than any other single brand. The For Dummies® brand is recognized by nearly 150 million U.S. adults and millions more in other countries.



8100

SERIES MOUNTS





MODEL # 8110		Low profile wall mount for small to medium size LCD TVs and monitors		
 Silver UPC: 748249781105	 Piano Black UPC: 748249081106	Estimated TV Size* 12" - 30" standard, 23" - 52" with optional 8190 adapter	Mounting Configuration <i>Standard</i> 75 x 75, 100 x 100 <i>*With Adapter 8190</i> 200 x 100, 200 x 150, 200 x 200	Fixed Mount
		Weight Capacity 175lbs 80kg	Worldwide Patents Pending	
Special Features Can be used with medium size TVs using the 8190 Adapter.				

MODEL # 8120		Tilting wall mount for small to medium size LCD TVs and monitors		
 Silver UPC: 748249781204	 Piano Black UPC: 748249081205	Estimated TV Size* 12" - 30" standard, 23" - 52" with optional 8190 adapter	Mounting Configuration <i>Standard</i> 75 x 75, 100 x 100 <i>*With Adapter 8190</i> 200 x 100, 200 x 150, 200 x 200	Tilt +15°/-5°
		Weight Capacity 150lbs 68kg	Worldwide Patents Pending	
Special Features Can be used with medium size TVs using the 8190 Adapter.				

MODEL # 8140		Full motion tilt/pan mount for small to medium size LCD TVs and monitors		
 Silver UPC: 748249781402	 Piano Black UPC: 748249081403	Estimated TV Size* 12" - 30" standard, 23" - 52" with optional 8190 adapter	Mounting Configuration <i>Standard</i> 75 x 75, 100 x 100 <i>*With Adapter 8190</i> 200 x 100, 200 x 150, 200 x 200	Tilt/Rotate +15°/-5°, Full Pan
		Weight Capacity 80lbs 36kg	Worldwide Patents Pending	
Special Features Can be used with medium size TVs using the 8190 Adapter. Built in Allen key storage.				

MODEL # 8160		Full motion tilt/pan mount for small to medium size LCD TVs and monitors		
 <p>Silver UPC: 748249781600</p> <p>Piano Black UPC: 748249081601</p>		Estimated TV Size* 12" - 30" standard, 23" - 46" with optional 8190 adapter	Mounting Configuration <i>Standard</i> 75 x 75, 100 x 100 *With Adapter 8190 200 x 100, 200 x 150, 200 x 200	Tilt/Rotate +20°/-15°, Full Pan
		Weight Capacity 65lbs 30kg	Arm Extension From: 2.75" to 10" (6.99 cm to 25.4 cm)	
Special Features Can be used with medium size TVs using the 8190 Adapter. Built in Allen key storage. Integrated Cable Management.				

MODEL # 8165		Full motion tilt/pan/articulating mount for small to medium size LCD TVs and monitors		
 <p>Silver UPC: 748249781655</p> <p>Piano Black UPC: 748249081656</p>		Estimated TV Size* 12" - 30" standard, 23" - 40" with optional 8190 adapter	Mounting Configuration <i>Standard</i> 75 x 75, 100 x 100 *With Adapter 8190 200 x 100, 200 x 150, 200 x 200	Tilt/Rotate +20°/-15°, Full Pan
		Weight Capacity 50lbs 23kg	Arm Extension From: 2.75" to 16" (6.99 cm to 40.64 cm)	
Special Features Can be used with medium size TVs using the 8190 Adapter. Built in Allen key storage. Integrated Cable Management.				

MODEL # 8170		Full motion tilt/pan/articulating mount for small to medium size LCD TVs and monitors		
8190 Adapter Included		Estimated TV Size* 12" - 52" with <u>included</u> 8190 adapter	Mounting Configuration <i>Standard</i> 75 x 75, 100 x 100, 200 x 100, 200 x 150, 200 x 200	Tilt/Rotate +20°/-15°, Full Pan
 <p>Silver UPC: 748249781709</p> <p>Piano Black UPC: 748249081700</p>				Weight Capacity 80lbs 36kg
Worldwide Patents Pending				
Special Features Can be used with medium size TVs using the included 8190 Adapter. Built in Allen key storage. Internal Cable Management.				

MODEL # 8190		Adapter plate to convert all 8100 Series mounts		
 <p>Silver UPC: 748249781907</p> <p>Piano Black UPC: 748249081908</p>		Weight Capacity 130lbs 59kg	TV Mount Compatibility* Fits 8100 series mounts: 8110, 8120, 8140, 8160 and 8165 (included with 8170)	Worldwide Patents Pending
		Special Features This low cost adapter provides a way to reduce inventory by converting any of the 8100 Series mounts to a 200 x 100, 200 x 150, 200 x 200 hole configuration.		

8300

SERIES MOUNTS



MODEL # 8310		Low profile fixed wall mount for large size LCD and Plasma TVs and monitors		
	Estimated TV Size* 30" - 50"	Mounting Configuration <i>Medium-Large Universal</i>	Worldwide Patents Pending	
	Weight Capacity 200lbs 91kg	Up to: 700 x 440mm (27.5" x 17.3")		
Special Features Decorative end caps provide a finished look to any installation. Twist lock system provides an easy way to secure the monitor brackets onto the wall plate. Can be pad locked.				
Silver UPC: 748249783109	Piano Black UPC: 748249083100			

MODEL # 8315		Low profile tilting wall mount for large size LCD and Plasma TVs and monitors		
	Estimated TV Size* 30" - 50"	Mounting Configuration <i>Medium-Large Universal</i>	Tilt/Rotate +15°/ -5° Tilt	
	Weight Capacity 200lbs 91kg	Up to: 700 x 440mm (27.5" x 17.3")	Worldwide Patents Pending	
Special Features Decorative end caps provide a finished look to any installation. Twist lock system provides an easy way to secure the monitor brackets onto the wall plate. Can be pad locked.				
Silver UPC: 748249783154	Piano Black UPC: 748249083155			

MODEL # 8320		Low profile fixed or 5 degree tilt wall mount for large to extra large size LCD and Plasma TVs and monitors		
	Estimated TV Size* 30" - 60"	Mounting Configuration <i>Large-Extra Large Universal</i>	Tilt 5° or parallel to wall	
	Weight Capacity 200lbs 91kg	Up to: 780 x 440mm (30.7" x 17.3")	Worldwide Patents Pending	
Special Features Decorative end caps provide a finished look to any installation. Included 5 degree tilt adapter allows you to mount the television flat or at a 5 degree down tilt. Twist lock system provides an easy way to secure the monitor brackets onto the wall plate. Can be pad locked.				
Silver UPC: 748249783208	Piano Black UPC: 748249083209			

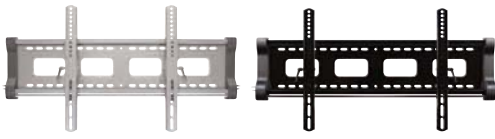
MODEL # 8325		Tilting wall mount for large to extra large size LCD and Plasma TVs and monitors		
	Estimated TV Size* 30" - 60"	Mounting Configuration <i>Large-Extra Large Universal</i>	Tilt +15°/-5°	Special Features Decorative end caps provide a finished look to any installation. Twist lock system provides an easy way to secure the monitor brackets onto the wall plate. Can be pad locked.
	Weight Capacity 200lbs 91kg			
	Worldwide Patents Pending	Up to: 780 x 440mm (30.7" x 17.3")		
Silver UPC: 748249783253	Piano Black UPC: 748249083254			

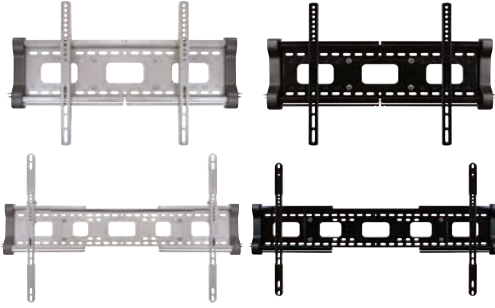
MODEL # 8330		Low profile fixed or 5 degree tilt wall mount for medium to extra large size LCD and Plasma TVs and monitors		
	Estimated TV Size* 27" - 84"	Mounting Configuration <i>Medium-Extra Large Universal</i>	Tilt 5° or parallel to wall	Special Features Decorative end caps provide a finished look to any installation. Included 5 degree tilt adapter allows you to mount the television flat or at a 5 degree down tilt. Twist lock system provides an easy way to secure the monitor brackets onto the wall plate. Can be pad locked. Expandable mount allows a perfect fit to almost any TV.
	Weight Capacity 280lbs 127kg			
	Worldwide Patents Pending	Non-Expanded-Up to: 635 x 440mm (25" x 17.3")		
		Expanded-Up to: 1055 x 660mm (41.5" x 26")		
Silver UPC: 748249783307	Piano Black UPC: 748249083308			

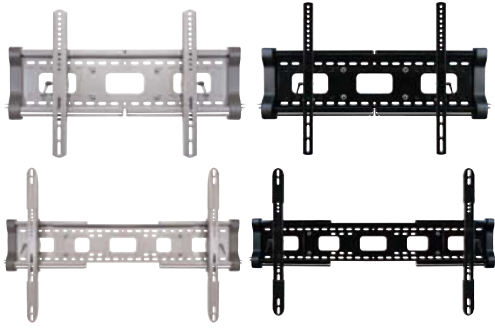
MODEL # 8335		Tilting wall mount for medium to extra large size LCD and Plasma TVs and monitors		
	Estimated TV Size* 27" - 84"	Mounting Configuration <i>Medium-Extra Large Universal</i>	Tilt +15°/-5°	Special Features Decorative end caps provide a finished look to any installation. Twist lock system provides an easy way to secure the monitor brackets onto the wall plate. Can be pad locked. Expandable mount allows a perfect fit to almost any TV.
	Weight Capacity 280lbs 127kg			
	Worldwide Patents Pending	Non-Expanded-Up to: 635 x 440mm (25" x 17.3")		
		Expanded-Up to: 1055 x 660mm (41.5" x 26")		
Silver UPC: 748249783352	Piano Black UPC: 748249083353			

* To select the correct mount first match the mounting hole configuration of your TV to the mount. You may need to use an adapter plate along with your TV. Then make sure the weight of the TV (and adapter, if applicable) does not exceed the weight rating of the mount.



Quite possibly the world's easiest mounts to install!



- ✓ Lifetime Warranty
- ✓ Solid heavy-gauge steel construction
- ✓ Durable powder-coated piano black or silver finish
- ✓ Attractive and functional design

Quick Reference Guide

Product Image*	Product Number	Type of Mount	Estimated TV Size	Weight Capacity	Mounting Configurations							
					75 mm x 75 mm	100 mm x 100 mm	200 mm x 100 mm	200 mm x 150 mm	200 mm x 200 mm	Medium Universal	Large Universal	XL Universal
	8110DB 8110DS	Fixed Mount	12-52"	175 lbs 80 kgs	✓	✓	Use Adapter 8190	Use Adapter 8190	Use Adapter 8190			
	8120DB 8120DS	Tilt Mount	12-52"	150 lbs 68 kgs	✓	✓	Use Adapter 8190	Use Adapter 8190	Use Adapter 8190			
	8140DB 8140DS	Tilt/Pan	12-52"	80 lbs 36 kgs	✓	✓	Use Adapter 8190	Use Adapter 8190	Use Adapter 8190			
	8160DB 8160DS	Tilt/Pan/ Cantilever	12-52"	65 lbs 30 kgs	✓	✓	Use Adapter 8190	Use Adapter 8190	Use Adapter 8190			
	8165DB 8165DS	Tilt/Pan/ Articulating	12-40"	50 lbs 23 kgs	✓	✓	Use Adapter 8190	Use Adapter 8190	Use Adapter 8190			
	8170DB 8170DS	Tilt/Pan/ Articulating	12-52"	80 lbs 36 kgs	✓	✓	✓	✓	✓			
	8190DB 8190DS	200 mm Adapter	Fits 8100 Series Mounts	130 lbs 59 kgs			✓	✓	✓			
	8310DB 8310DS	Medium Fixed Mount	30-50"	130 lbs 59 kgs						Up to: 700 x 440mm 27.5" x 17.3"		
	8315DB 8315DS	Medium Tilt Mount	30-50"	130 lbs 59 kgs						Up to: 700 x 440mm 27.5" x 17.3"		
	8320DB 8320DS	Large Fixed Mount	30-63"	200 lbs 91 kgs						Up to: 780 x 440mm 30.7" x 17.3"		
	8325DB 8325DS	Large Tilt Mount	30-63"	200 lbs 91 kgs						Up to: 780 x 440mm 30.7" x 17.3"		
	8330DB 8330DS	Extra Large Fixed Mount	27-84"	280 lbs 127 kgs						Non Expanded-Up to: 635 x 440mm 25" x 17.3" Expanded-Up to: 1055 x 660mm 41.5" x 26"		
	8335DB 8335DS	Extra Large Tilt Mount	27-84"	280 lbs 127 kgs						Non Expanded-Up to: 635 x 440mm 25" x 17.3" Expanded-Up to: 1055 x 660mm 41.5" x 26"		

*All mounts available in Piano Black (DB) and Silver (DS)



Bell'O International Corporation

711 Ginesi Drive • Morganville, NJ 07751
Phone: 732.972.1333 • Fax: 732.536.6482
Email: sales@bello.com • www.bello.com

FOR
DUMMIES[®]
A Branded Imprint of  WILEY
Now you know.

*Wiley, the Wiley logo, For Dummies, the Dummies Man logo,
and related trademarks are registered trademarks of John Wiley
& Sons, Inc. and/or its affiliates. Used by license.*

